



iPA-4U-WN400 + A4001



Adaptable **electro-hydraulic** power,  
engineered for seamless integration and  
control

Learn more

[Inetictraction.com](http://Inetictraction.com)

Inetic

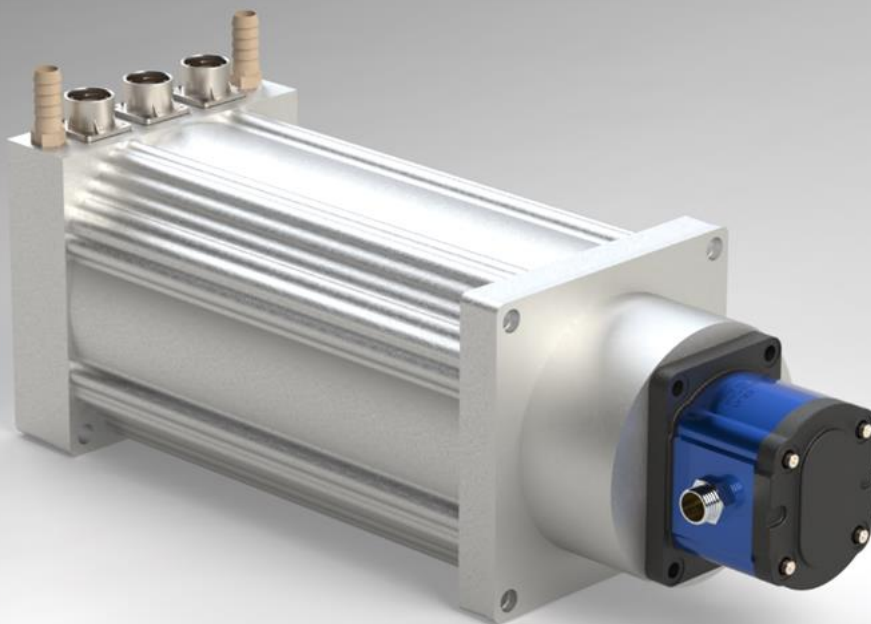

# iPA-4U-WN400 + A4001



## Pump Coupling



The motor is shown integrated with both a new off-the-shelf hydraulic gear pump using standard fittings, and an existing vehicle pump—demonstrating its flexibility for new designs as well as retrofit applications. This adaptability enables seamless integration across a range of platforms and use cases.

## Inverter Data

Electrical Specification	UNIT	
DC link voltage	VDC	250-420
Max Operational Voltage	VDC	420
Max Current	Arms	410
Continuous Power @400V	kw	150
LV Supply	VDC	9-18
Switching Frequency	kHz	10

Performance Specification		
Working Temperature	°C	-40 to 85
Cooling		Water-Glycol 50:50
Mass	Kg	11.2
Flow Rate	l/m	12-16

# iPA-4U-WN400 + A4001



## Motor Data

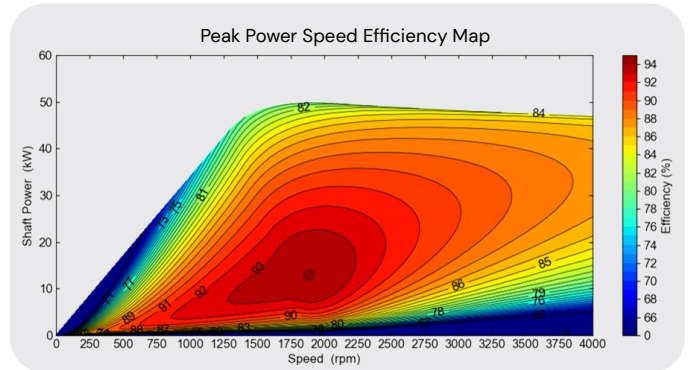
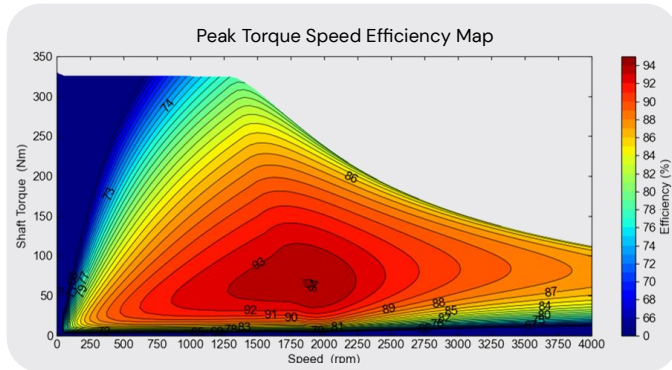

Electrical Specification	UNIT	
Motor / Generator Type	3-Phase Radial Synchronous Flux Permanent Magnet Motor/Generator	
Applications	Electro-hydraulic, Off-highway, Warehouse automation	
Maximum DC Voltage (Motor)	VDC	420
Maximum Phase Current (Motor)	Arms	410
Rotor Position Sensor	Resolver	

Performance Specification	UNIT	
Peak Torque (For 10s)	Nm	325
Peak Power (For 10s)	kw	48
Continuous Torque	Nm	148
Continuous Power	kw	33
Torque Density Peak	Nm/L	57
Power Density Peak	kW/L	8

Mechanical Specification	UNIT	
Cross Section Dimension	mm	180x180
Package Length (Excluding Shaft)	mm	381
Mass	kg	54
Maximum Speed	rpm	4,000
Axial/Radial Shaft Load	N	100N Axial, 200N Radial
Ingress Protection	IP	IP67
Motor Connection Type	PowerLok Connectors	
Cogging Torque	Nm	<2.5%

Thermal Specification	UNIT	
Cooling Method	Water-Glycol 50:50	
Coolant Inlet Temperature	°C	-10 to 85
Coolant Inlet Pressure	bar (gauge)	0.5-3.0
Maximum Stator Winding Temperature	°C	180
De-Rate Stator Winding Temperature	°C	165
Temperature Sensor	-	PT1000
Ambient Temperature	°C	-20 to 100

NOTE: 1) Mass: excludes cables and coolant tubes, 2) Peak Values are simulated using 400VDC and 410Arms, 3) Continuous Values are simulated using 400VDC, 70°C inlet temperature and 12l/m flow rate, 4) The data provided in this datasheet is for guidance only and does not form part of any contract. 5) Motor, inverter, gearbox should undergo application testing to validate performance.

# iPA-4U-WN400 + A4001



## Motor Geometry

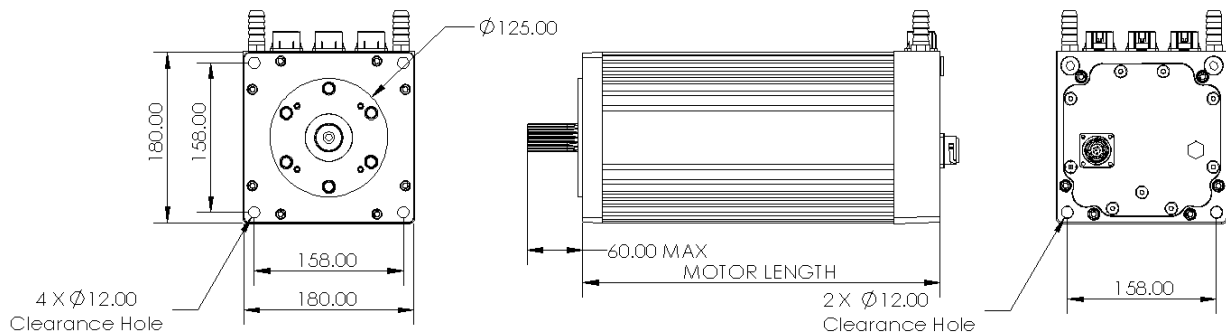

## Inverter Geometry

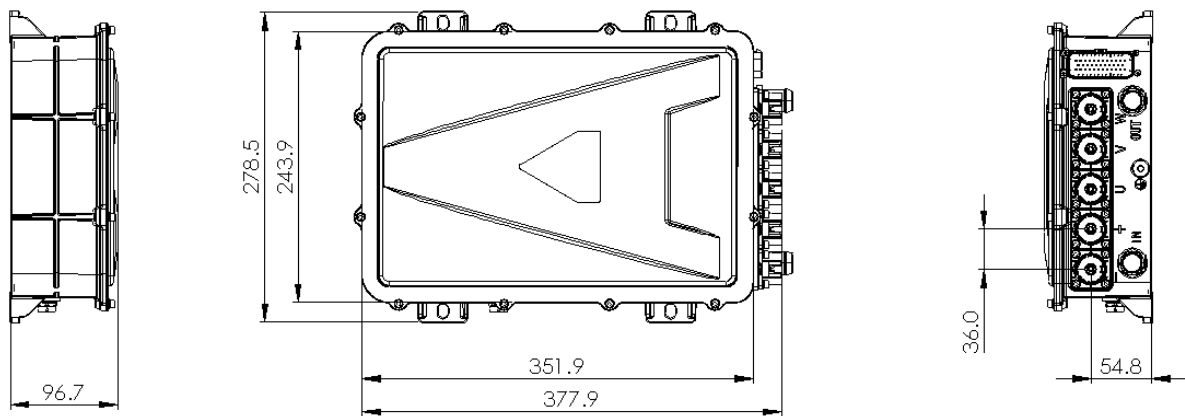

Explore [inetictraction.com](https://inetictraction.com) to design your drive system with multiple configurations, and control systems